

4

3

2

1

SHOWN IN FORWARD EXTENDED SHAFT POSITION

REVISIONS					
ZONE	LETTER	DESCRIPTION	DATE	CHECKED	APPROVED

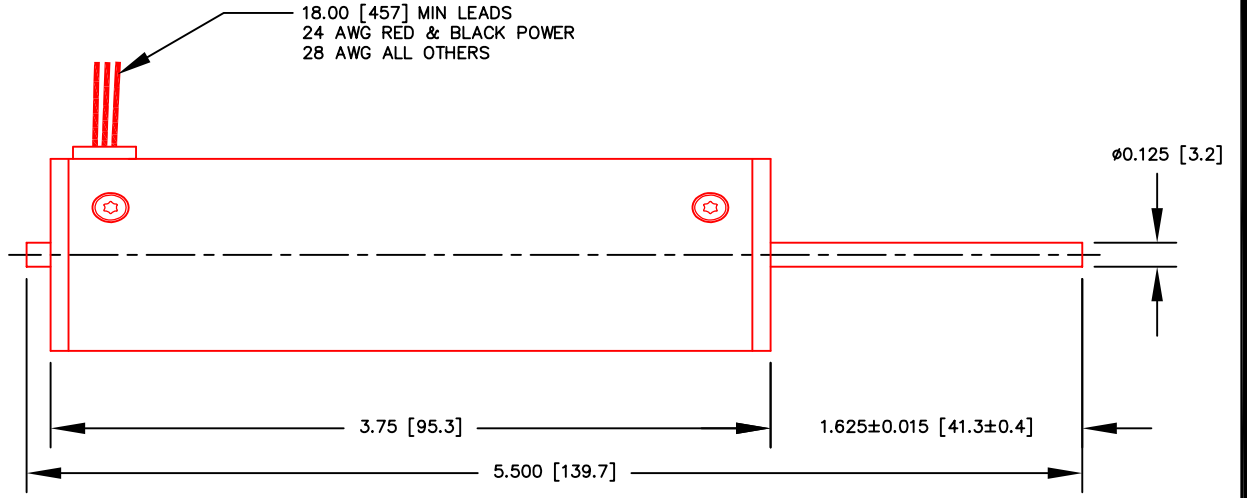
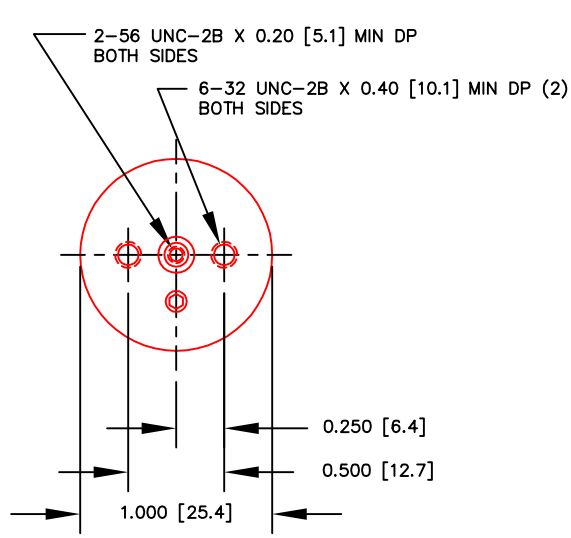

ENCODER RESOLUTION	5.00 $\mu$ m	0.000197 IN
INTERMITTENT FORCE @10% DUTY CYCLE	18.5 N	66.4 OZ
CONTINUOUS FORCE	5.8 N	21.0 OZ
FORCE CONSTANT	4.24 N/A	15.3 OZ/A
BACK EMF CONSTANT	4.24 V/M/S	0.11 V/IN/S
STROKE	25.4 mm	1.000 IN
MOVING MASS	54 GR	1.91 OZ
TOTAL MASS	240 GR	8.5 OZ
COIL RESISTANCE	5.3 Ohms	
COIL INDUCTANCE @ 1000 Hz	2.6 mH	
MAX CONTINUOUS POWER	10.0 W	
MAX TOTAL SHAFT SIDE LOAD	2.0 N	7.2 OZ
LINEAR BEARING TYPE	PLAIN BUSHING	

COLOR	DESCRIPTION
ORANGE	+5 VDC POWER FOR OPTICAL ENCODER
GREEN	CHANNEL A OUTPUT OF OPTICAL ENCODER, TTL
WHITE	CHANNEL B OUTPUT OF OPTICAL ENCODER, TTL
BROWN	RETURN FOR OPTICAL ENCODER
BLACK	MOTOR MINUS
RED	MOTOR PLUS
GRAY	HOME INDICATOR, TTL, ACTIVE HIGH

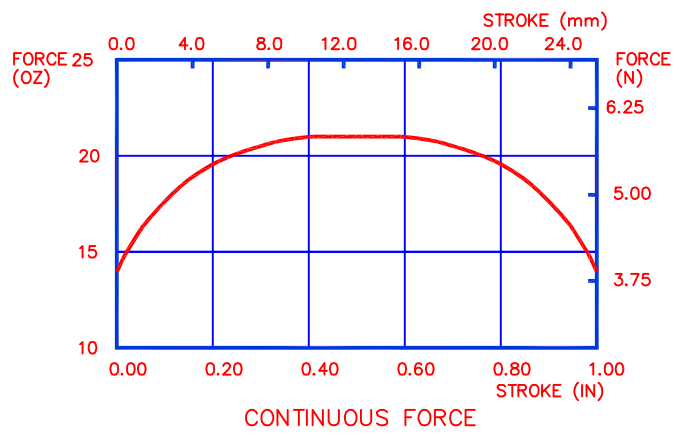

THIS DOCUMENT, WHETHER OR NOT MARKED AS PROPRIETARY, IS CONSIDERED CONFIDENTIAL AND SHALL REMAIN THE PROPERTY OF MOTICONT AND SHALL BE RETURNED TO MOTICONT UPON REQUEST WITH ALL COPIES MADE THEREOF. THIS DOCUMENT CANNOT BE UTILIZED IN THE MANUFACTURE OF ARTICLES SOLD OR OFFERED OR DISCLOSED TO ANYONE AND NO USE OF IT CAN BE MADE UNLESS EXPRESSLY AUTHORIZED BY AND UNDER THE DIRECTION OF MOTICONT. POSSESSION OF THIS DOCUMENT IS ACCEPTED SUBJECT TO THE FOREGOING.

3-MOTOR MAY BE SUPPLIED WITH OPTIONAL SPRINGS.  
 2-FOR PROPER HEAT DISSIPATION, THE MOTOR SHOULD BE MOUNTED ON A METALLIC BODY WITH ADEQUATE SURFACE AREA IN AN UNRESTRICTED FLOW OF AIR.  
 1-ALL VALUES AT 25°C

NOTES:  
 UNLESS OTHERWISE SPECIFIED

DIMENSIONS ARE IN INCHES (mm)	
TOLERANCES ON:	
DECIMALS	FRACTIONS
.XXX	± 1/125
.XX	± 1/2'
± .005 ± .01	
UNLESS OTHERWISE SPECIFIED	
USED ON	NEXT ASSY
APPLICATION	

MATERIAL	CONTRACT	
FINISH	DRN	
	CHKD	
	APPVD	
	APPVD	

motiCONT			
LINEAR DIRECT DRIVE MOTOR WITH BUILT-IN ENCODER			
SIZE	CODE	DWG. NO.	REV.
A		SDLM-025-095-01-05	2
SCALE: 1 / 1		SHEET 1 OF 1	

4

3

2

1