

Digital Servo Motor Driver

Description

This 500 series digital servo drive is designed to drive brushed and brushless servomotors from a compact form factor. This fully digital drive operates in torque, velocity, or position mode and employs Space Vector Modulation (SVM), which results in higher bus voltage utilization and reduced heat dissipation compared to traditional PWM. The command source can be generated internally for testing or can be supplied externally. In addition to motor control, this drive features dedicated and programmable digital and analog inputs and outputs to enhance interfacing with external controllers and devices.

The drive features an RS-232 interface for drive configuration and setup.

All drive and motor parameters are stored in non-volatile memory.

Power Range

Peak Current	12 A (8.5 A _{RMS})
Continuous Current	6 A (4.2 A _{RMS})
Supply Voltage	20 - 80 VDC

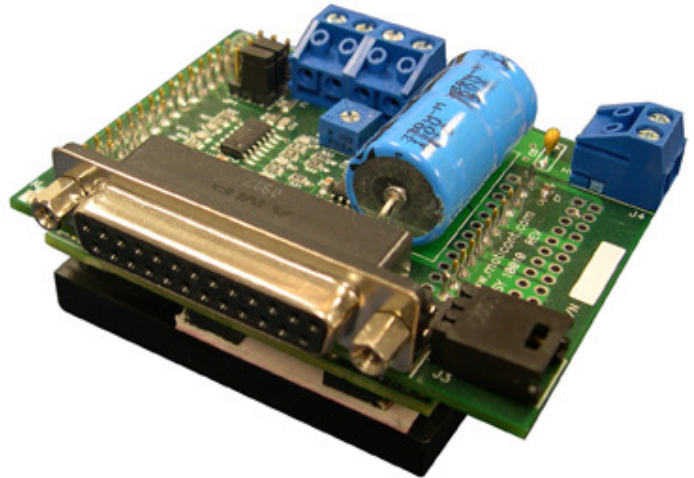

Features

- ▲ Four Quadrant Regenerative Operation
- ▲ Space Vector Modulation (SVM) Technology
- ▲ Fully Digital State-of-the-art Design
- ▲ Programmable Gain Settings
- ▲ Fully Configurable Current, Voltage, Velocity and Position Limits
- ▲ PIDF Velocity Loop
- ▲ PID + FF Position Loop
- ▲ Compact size, high power density
- ▲ 12-bit Analog to Digital Hardware

MODES OF OPERATION

- Current
- Position
- Velocity

COMMAND SOURCE

- ± 10 V Analog
- +5V Step and Direction

FEEDBACK SUPPORTED

- Hall Effect Sensor
- Incremental Encoder
- ± 10 V Analog
- Auxiliary Incremental Encoder

Digital Servo Motor Driver

SPECIFICATIONS

Power Specifications		
Description	Units	Value
DC Supply Voltage Range	VDC	20 - 80
DC Bus Over Voltage Limit	VDC	86
DC Bus Under Voltage Limit	VDC	17
Logic Supply Voltage	VDC	5
Maximum Peak Output Current	A (Arms)	12 (8.5)
Maximum Continuous Output Current	A (Arms)	6 (4.2)
Internal Bus Capacitance	μF	330
Minimum Load Inductance (Line-To-Line) ¹	μH	250
Switching Frequency	kHz	20
Control Specifications		
Description	Units	Value
Communication Interfaces	-	RS-232
Command Sources	-	±10 V Analog, 5V Step and Direction, Encoder Following
Feedback Supported	-	±10 V Analog, Auxiliary Incremental Encoder, Halls, Incremental Encoder
Commutation Methods	-	Sinusoidal, Trapezoidal
Modes of Operation	-	Current, Position, Velocity
Motors Supported	-	Brushed, Brushless, Voice Coil
Hardware Protection	-	40+ Configurable Functions, Over Current, Over Temperature (Drive & Motor), Over Voltage, Short Circuit (Phase-Phase & Phase-Ground), Under Voltage
Programmable Digital Inputs	-	2
Programmable Analog Inputs	-	1
Current Loop Sample Time	μs	50
Velocity Loop Sample Time	μs	100
Position Loop Sample Time	μs	100
Maximum Encoder Frequency	MHz	20 (5 pre-quadrature)
Mechanical Specifications		
Description	Units	Value
Weight	g (oz)	159 (5.6)
Heatsink (Base) Temperature Range ²	°C (°F)	0 - 65 (32 - 149)
Storage Temperature Range	°C (°F)	-40 - 85 (-40 - 185)
Cooling System	-	Natural Convection
Form Factor	-	Chassis Mounted

Notes

1. Lower inductance is acceptable for bus voltages well below maximum. Use external inductance to meet requirements.
2. Additional cooling and/or heatsink may be required to achieve rated performance.

Digital Servo Motor Driver

PIN FUNCTIONS

J2 - Signal Connector, DB-25 Female			
Pin	Name	Description / Notes	I/O
1	+5 VDC	+5 VDC Input / Output	I - O
2	STEP	Step Signal	I
3	DIRECTION	Direction Signal	I
4		Not Connected	
5	MOT ENC B+	Motor Encoder B+ Channel Input	I
6	MOT ENC A+	Motor Encoder A+ Channel Input	I
7	GND	Ground	GND
8	MOT ENC I+	Motor Encoder I+ Channel Input	I
9	HALL-B	Single-ended Commutation Sensor Input - B	I
10	+5 VDC	+5 VDC Input / Output	I-O
11	HALL-A	Single-ended Commutation Sensor Input - A	I
12	PDI-4	Not Connected	I
13	REF-	Negative Side of Differential Programmable Analog Input or Reference Signal Input	I
14	GND	Ground	
15		Not Connected	
16		Not Connected	
17		Not Connected	
18	MOT ENC B-	Motor Encoder B- Channel Input	I
19	MOT ENC A-	Motor Encoder A- Channel Input	I
20	+5 VDC	+5 VDC Input / Output	I-O
21	MOT ENC I-	Motor Encoder I- Channel Input	I
22	GND	Ground	
23	HALL-C	Single-ended Commutation Sensor Input - C	I
24			I
25	REF+	Positive Side of Differential Programmable Analog Input or Reference Signal Input	I

J4 - Power Connector, Screw Terminal			
Pin	Name	Description / Notes	I/O
G	GND	Ground	GND
HV	HIGH VOLTAGE	DC Power Input	I

J5 - Motor Connector, Screw Terminal			
Pin	Name	Description / Notes	I/O
C	MOTOR C	Motor Phase C	O
B	MOTOR B	Motor Phase B	O
A	MOTOR A	Motor Phase A	O
G	GND	Ground	GND

J3 - RS232 Connector, DB-9 Female			
Pin	Name	Description / Notes	I/O
1	RS232 RX	Receive Line	I
2	RS232 TX	Transmit Line	O
3	GND	Ground	GND

SPECIFICATIONS ARE SUBJECT TO CHANGE WITHOUT NOTICE

Digital Servo Motor Driver

DIMENSIONS

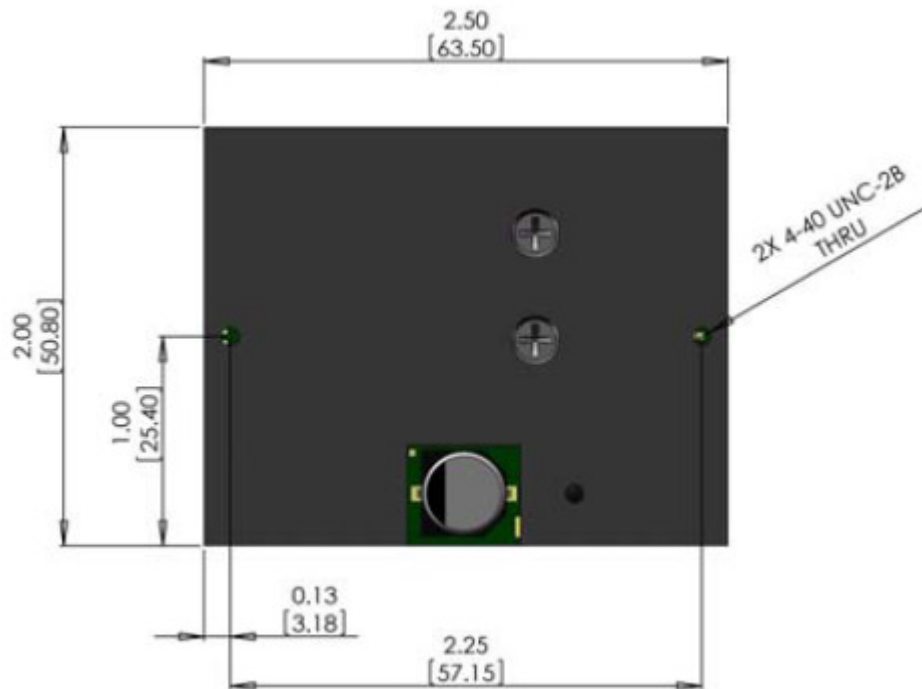

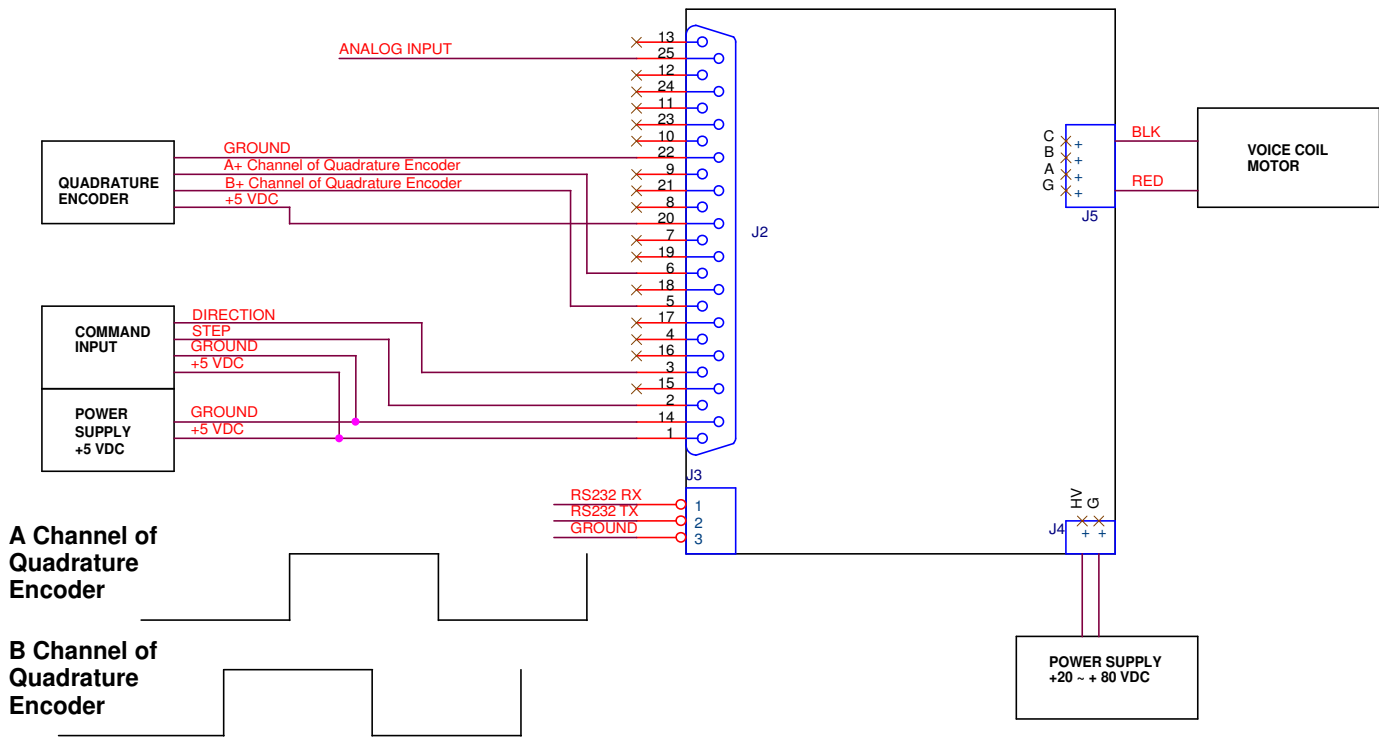

Encoder Phase Relationship when the Motor Is Moving Outward.

DC MOTOR CONTROL with STEP and DIRECTION COMMAND INPUT or ANALOG INPUT

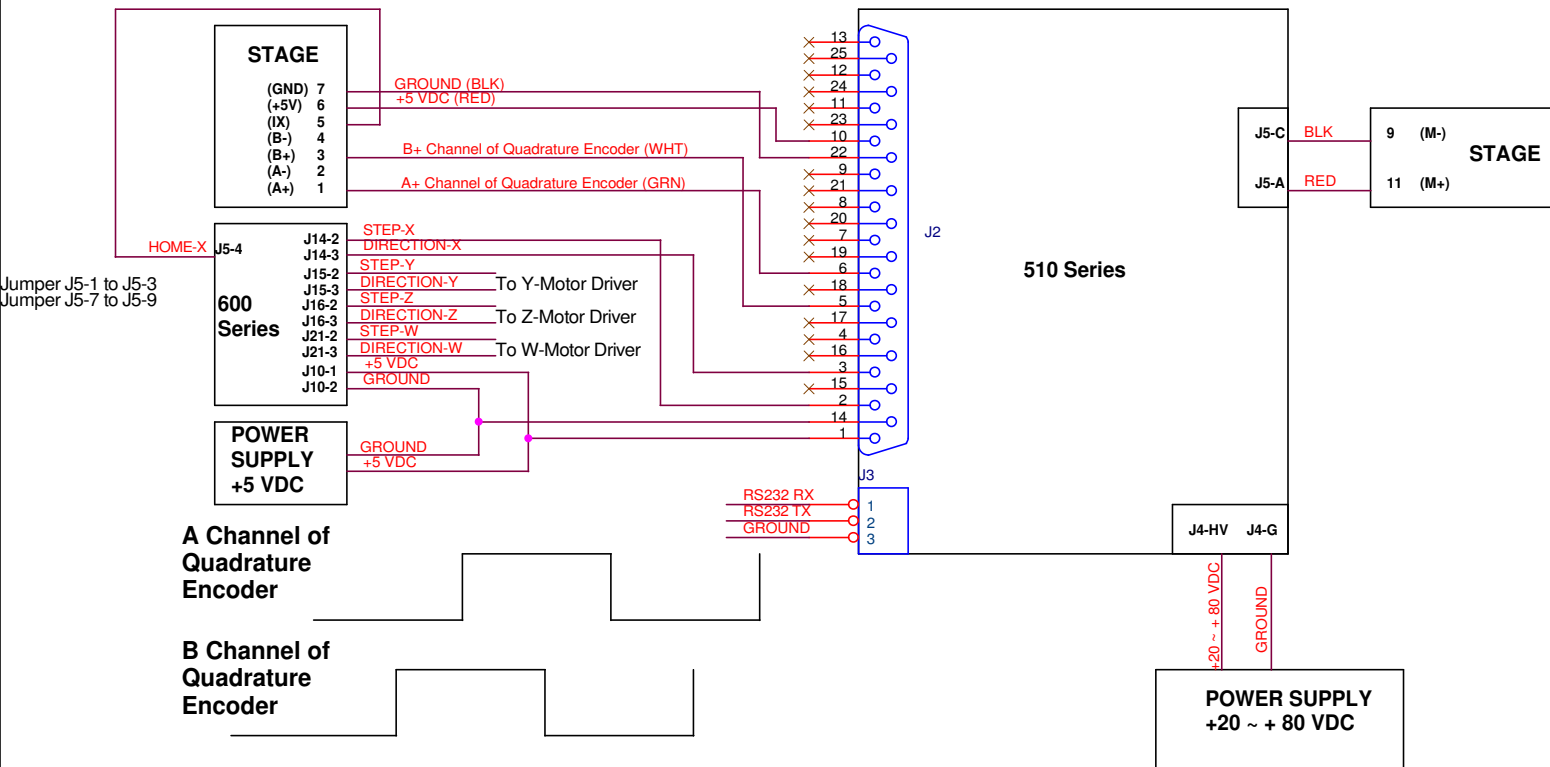

Moticont
 6901 Woodley Avenue
 Van Nuys, California 91406 U.S.A
 www.moticont.com

TEL +1 (818) 785-1800
 FAX +1 (818) 785-5713
 moticont@moticont.com